

RANGE (TIME BASE) CONTROL

Time Base, Output Switching

NOTE: Refer to Area J in Fig. 4.6.

4.26 The time base chain comprises the decade dividers IC10 to IC14, the various timing signals being obtained from pin 8 of IC6c and pin 11 of each decade package. An output is selected by a contact on the push-buttons S2a to S2f respectively and connected to the inverter Q25. From Q25 the selected signal is fed to the control circuit gating via IC4c or to the counter gating via IC18e.

Time Base Input Gating

NOTE: Refer to Area H on Fig. 4.6.

4.27 The particular input signal which drives the time base is determined by the Function switch. The driving signal may be either a 10 kHz or 1 MHz reference derived from the frequency standard or an external signal via input channels 'A' or 'B'. The time base gating circuit (IC9a, b and c, IC5c and IC6) selects the correct input in accordance with logic signals supplied via switch S1. The details of the time base input paths are as follows:-

<u>Function</u>	<u>Time Base Input Source</u>
Frequency ...	10 kHz reference from IC2 via IC9b.
Period	Signal from 'A' channel via IC22f.
Time Interval	1 MHz reference from IC24c via IC9a.
Ratio	Signal from 'B' channel via IC21c.
Totalize	Same as Period mode.

4.28 The time base input gating operates as follows:-

- (a) On Period and Totalize the 'A' channel signals are fed via IC6d, the two modes being logically detected by IC8c.
- (b) On Ratio the 'B' channel signals are fed via IC6e, the mode being logically detected via IC19a.
- (c) On Frequency and Time Interval modes the frequency standard signal at IC6a/13 is fed to the time base, the mode logic on IC6a/1 being detected via IC5c (which argues logically that because neither Period, Ratio nor Totalize modes are called up the required mode must be Frequency or Time Interval). These two modes require different reference frequencies,

thus necessitating a subsidiary detection process in IC9a and b between the 10 kHz and 1 MHz frequency standards. The 10 kHz signal is fed through IC9b/9 on Frequency mode, detection being by IC8d, otherwise the 1 MHz signal passes through IC9a to IC6a.

COUNTER GATING CIRCUIT

NOTE: Refer to Area E in Fig. 4.6.

Signal Paths and Main Gate

4.29 The function of the counter gating circuit is to release the appropriate type of signal to the counter for an accurately timed period. Selection of signal input is made by the Function switch in conjunction with resistors R67 to R71 (see para. 4.12) and IC's 18a, 18d and 18e, the actual timing of the count period being controlled in the Main Gate IC18c by the waveform generated in the Control Circuit (IC16a) and applied via TP1 and IC18b. (see para. 4.33). Whilst the Main Gate is open the signal is fed via pin 9 of the Motherboard to the counting chain in the Counter Display Assembly.

Counter Gating

4.30 The relationship between Function switch setting and signal selection is as follows:-

<u>Function</u>	<u>Signal Offered to IC18c</u>	<u>Input Path</u>	<u>Mode Detection</u>
Frequency	Channel 'A'	IC18a, IC22f	Via IC19b
Period	1 MHz (1 μ sec units)	IC18d, IC24c	Via IC19d
Time Int.	Time Base O/P	IC18e, Q25	Via IC17a
Ratio	Channel 'A'	Same as Frequency	
Total	Time Base O/P	Same as Time Int.	(See NOTE below)

NOTE: The selected time base signal for Time Interval and Totalize modes is fed via IC18e under control detected by IC17a. This gate (IC17a) argues that since neither the channel 'A' path nor the 1 MHz (Period) path is open, then the time base signal must be required.

MAIN CONTROL CIRCUIT

NOTE: Refer to Areas K and F in Fig. 4.6.

Introduction

4.31 The function of the Main Control Circuit is to provide waveforms for the following timing processes:-

- (a) Start/Stop signals in Time Interval and Totalize modes.
- (b) Control of the measurement period via the Main Gate IC18c.
- (c) Display Time Control.
- (d) Reset and Print Command.
- (e) Transfer pulse, which, when using a latched display, transfers the stored count to the display.

4.32 The Main Control Circuit itself is enclosed in Area K in Fig. 4.6, but the system of gates to the left of IC16a (Area F) determines the inputs to IC16a for each setting of the Function switch. A selection of Control Circuit waveforms is shown in Fig. 2.8. (page 4-9).

Main Gate Bistable IC16a

4.33 The timing waveform applied to the Main Gate (Fig. 2.8 waveform b) is generated in the D-Type bistable IC16a and extracted as the \bar{Q} output from pin 8. When IC16a is switched to the "set" condition (by an edge at either pin 10 or pin 11) it causes the \bar{Q} output to fall to 0V which via IC18b opens the Main Gate, thus allowing the signal to pass to the counter until IC16a is "restored" by a succeeding input edge. This causes the \bar{Q} to revert to the "high" level which closes the Main Gate, thus terminating the count period and initiating the display period.

Display Bistable IC16b

4.34 At the instant of Main Gate closure the positive-going edge on IC16a/8 triggers the Display Bistable IC16b which, via the Q output on pin 5 (Fig. 2.8 (d)) provides a print command output via R93 and also releases the 'hold' on the display time circuit as described in para. 4.36.

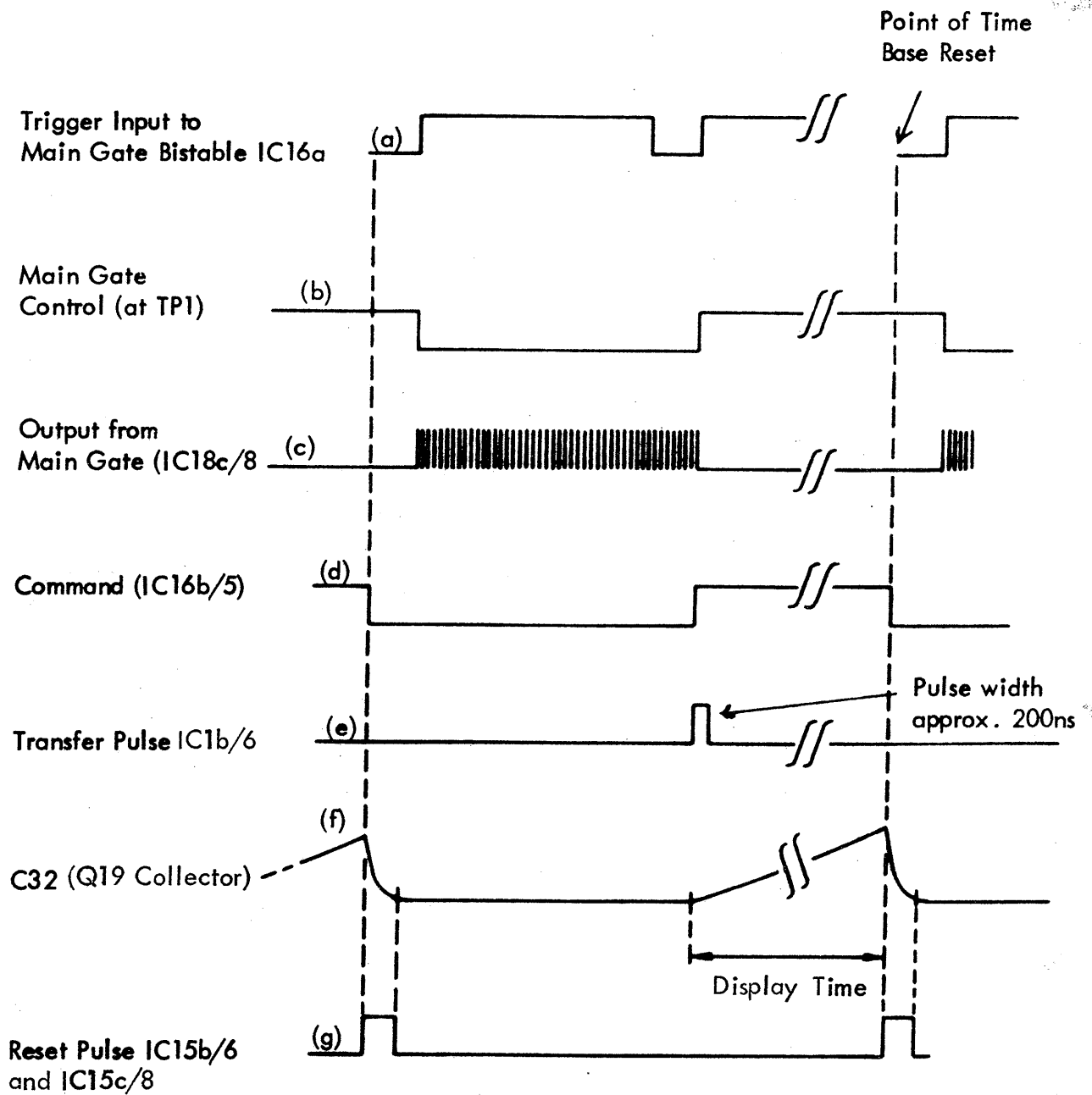

Waveforms: Main Control Circuit - Fig. 2.8

4.35 At the end of the display period a negative edge (Reset) is applied to IC16b/1 (Clear) which generates a 0V level at IC16b/5. This turns on Q19 which inhibits the display time generator during the ensuing measurement period.

Display Time Control and Print Command

4.36 The Display Time Generator comprises the clamping transistor Q19 and the regenerative switch Q20/Q21, the time constant being determined by C32 charging from +5V via R82 and the panel-mounted DISPLAY TIME potentiometer R152. Ganged with R152 is the switch S19, by turning R152 fully anti-clockwise to the "click" (Single Shot) position, switch S19 is opened and C32 cannot charge, thus preventing generation of a Reset pulse and maintaining the display indefinitely. A single update can be obtained by pressing the manual Reset button (S17).

4.37 At the instant of Main Gate closure the Q output from IC16b/5 goes to logic '1' which, inverted in IC15d, turns off Q19 thus removing the clamp from C32 which commences to charge through R82 and the Display Time potentiometer R152. Capacitor C32 charges until the voltage at Q20 emitter is taken above that at the base, (fixed by R89/R90) at which point Q20 begins to conduct, feeding current into Q21 base. This turns on Q21, bringing down the level at the junction of R89/R90 which turns Q20 on harder. This regenerative action results in a very rapid switch-on and C32 discharges via R85. The time taken for this discharge determines the width of the Reset pulse. (Fig. 2.8 (f) and (g)).

4.38 Reset Pulse. When the regenerative switch Q20/Q21 fires, the junction of R89/R90 falls sharply towards 0V, and shortly afterwards rises again as C32 becomes discharged. This is the Reset pulse which is fed to pins 5 and 10 of IC15 and appears as a positive pulse on pins 6 and 8 of that IC. (Fig. 2.8(g)). The Reset pulse from IC15c is fed to the Time Base and the Reset pulse from IC15b serves the Counter Display Assembly.

4.39 Function of Q18 and D5. The bistable package IC16 requires a negative reset pulse, whereas elsewhere in the instrument a positive reset is used. The necessary reset inversion for IC16 is provided by Q18. The diode D5 isolates the manual Stop line from the electronic reset line.

4.40 Transfer Pulse. This pulse is derived from the main gate closure edge at IC16a/9 this negative-going edge being differentiated by C33 and then inverted in IC1b, IC17b and Q22 from which it is fed as a positive pulse via pin 4 of the p.c.b. to the Counter Display Assembly, where, if the instrument is equipped for latched display, it transfers the new reading to the display. The purpose of IC17b is to simulate a condition of continuous transfer when operating in Time Interval and Totalize modes. The connection to IC17b/5 is in parallel with the Function gating on IC18e/4 which is also controlled on those two modes, thus an unlatched display is provided.

4.41 Manual Reset. When the RESET push-button S17 is depressed it places a 0V on IC1b, IC15b and IC15c. Referring to IC15b and c it is evident that this action generates a reset pulse identical in purpose to the electronic one; the application of this manual reset to IC1b generates a transfer pulse, which sets the display to zero at the same time as the counter is reset.

Start/Stop Push-Buttons

4.42 By depressing the START push-button (S15) 0V level is connected to the Main Gate Bistable IC16a/10. This toggles the bistable into the "main gate open" condition. By depressing the STOP push-button (S16) the 0V is applied to IC16a/13 which resets the bistable and closes the main gate.

External 'Hold' and Reset

4.43 On receipt of a Command pulse from the Control Circuit the data recording device (printer) will commence to print and at the same time will generate a 'Hold' signal which is applied to the instrument via pin 10 of the Motherboard. This inhibits any further measurement until the printer has recorded the data just received. At the end of the 'Hold' period the instrument is released to commence a new measurement. To avoid the unnecessary delay which would occur if the Display Time Generator were allowed to complete its cycle, provision is made for an artificial reset via IC15a with C34 and R91, the waveforms being shown in Fig. 2.9, below.

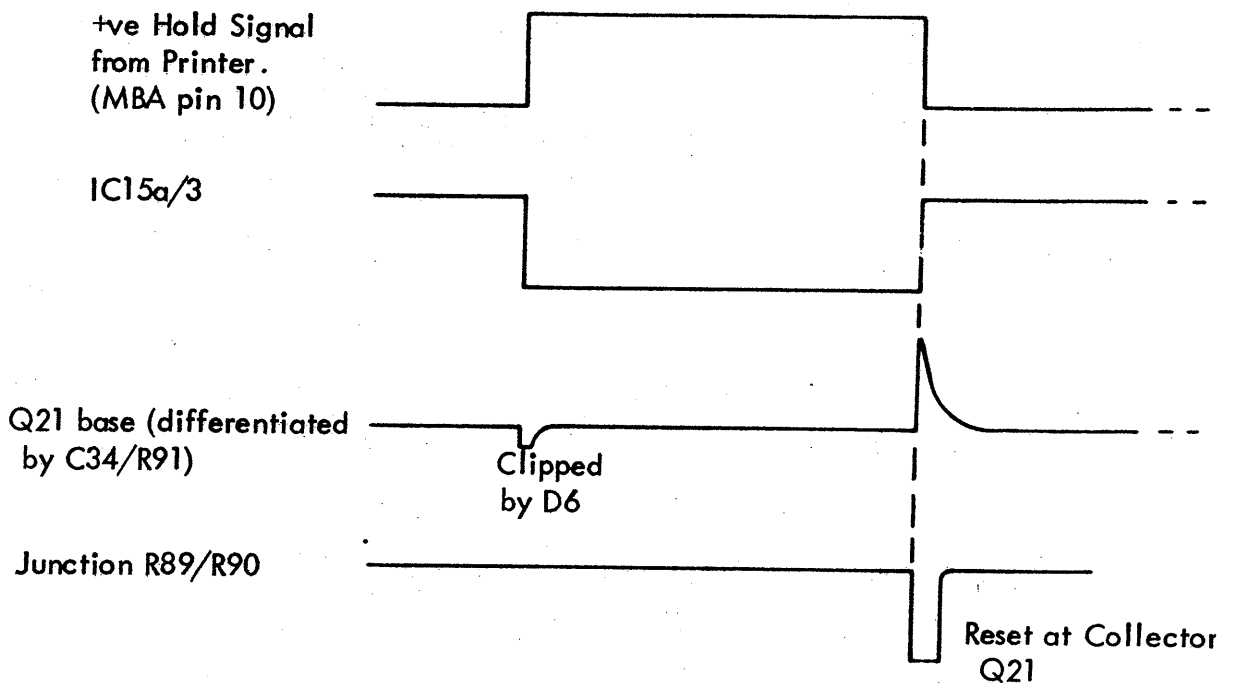

External Hold and Reset

Fig. 2.9

4.44 The positive 'hold' from the printer is inverted in IC15a and IC15d to clamp Q19 and prevent any charging of the display time capacitor C32 (para. 4.37). On completion of the printout the 'hold' input falls to 0V, this negative edge being inverted in IC15a and differentiated by C34/R91 to turn on Q21, which produces a negative pulse at the junction of R89/R90. This is similar in form to the Reset pulse generated by the Display Time Circuit as described in para. 4.38.

MAIN CONTROL CIRCUIT INPUT GATING

Introduction

4.45 This circuit, which is enclosed in Area F of Fig. 4.6, determines the type of signal fed to pin 11 of the main gate bistable IC16a. The choice of signal is controlled by the Function switch, as follows:-

- (a) On the Frequency, Period and Ratio modes the main gate bistable must be driven by an input from the time base. (See next paragraph).
- (b) On the Time Interval and Totalize modes the required drive is Start/Stop information from random events supplied via the input amplifiers and Trigger Slope gates (para. 4.54).

The selection between the signals in Group (a) or (b) is made by IC4a, b and c feeding into IC1a.

Input from the Time Base

4.46 The drive from the time base for Frequency Period and Ratio is gated in IC4c, the drive being fed to pin 9 and the gate being switched at pin 11 by logic signals derived from the Function switch detected via inverter IC17c from Counter Gating signals (see para. 4.30). During the display period this input to IC16a is inhibited by a signal from the display bistable applied to IC4c/10. (see para. 4.49).

'Start' and 'Stop' Gating

4.47 'Start' Line. The general Start line is from the 'B' channel amplifier via IC21c/8 to IC1c/11. Switching is on pins 9 and 10 of IC1c, which receive a logical '1' in the Time Interval and Totalize positions of the Function switch and this releases the Start signal via C30 to IC4b/5. It now remains to ensure that the Start signal is applied at the correct instant, this is the function of pin 4 on IC4b which, whilst the main gate bistable IC16a is at rest (i.e. waiting to start a measurement) will be

supplied with a logical '1' from the \bar{Q} output at IC16a/8, thus keeping IC4b open. It may be noted that at the same time the opposite level at IC16a/9 will be keeping the Stop gate IC4a closed (pin 1). When a Start signal is received, IC16a will toggle, which opens the Main Gate and at the same time reverses the states of IC4a/1 and IC4b/4.

4.48 'Stop' Lines. There are two sources of Stop signal to be considered, as follows:-

- (a) On Time Interval-Single Line, the Stop signal is supplied via the 'B' channel and IC21f, with preliminary gating selection being made in IC7e, which is opened for single-line Time Interval mode by a '1' on pin 4 applied via IC17d. On "double-line" mode, however, IC17d is inhibited by the '1' applied to pin 12, thus closing IC7e. The Stop signal is fed via IC7f and C31 to IC4a/13, this latter IC being opened to receive a Stop signal by the Q output ('1') level applied to pin 1 from the main gate bistable whenever the Main Gate is opened.
- (b) The alternative Stop signal occurs on Time Interval - Double Line, the source being the 'A' channel d.c. amplifier with routing via IC22c to IC7d/2, this latter IC being opened in the Time Interval B-A position of the Function switch via IC19c. From IC7d the Stop signal is routed via IC7f and C31 to IC4a/13, as above.

Control Circuit Input Inhibit

4.49 It is essential to inhibit all triggering of the Main Gate Bistable during the display period. This is ensured by feeding the \bar{Q} output from pin 6 of IC16b to pins 3, 2 and 10 of IC4, thus closing all triggering paths to IC16a from the moment that the display period commences until the general reset occurs.

D.C. AMPLIFIERS and PULSE/CONTACT SWITCH

NOTE: Refer to Area C in Fig. 4.6.

4.50 The 'A' Channel d.c. amplifier is Q11 and Q13 with Schmitt Trigger IC23a and the 'B' Channel employs an identical circuit around Q12, Q14 and IC23b. For both amplifiers the input trigger levels are arranged to be compatible with TTL circuitry and are nominally 1V above ground.

PULSE Position of Switch S14

4.51 Refer to Fig. 4.6 (Area C) and consider the 'B' Channel d.c. amplifier as an example. The input is on pin 34 and with switch S14 in the PULSE position, the resistors R42, R45 with R47, R49 and R51 are arranged to give a trigger point on IC23b which is equivalent to a nominal 1V above ground at pin 34. It will be noted that R40 is grounded through the PULSE connections of switch S14. Similar considerations apply to the 'A' channel d.c. amplifier.

CONTACT Position of S14.

4.52 Many users, particularly in industry, will need to trigger the instrument from contact closures, a requirement which is met by the CONTACT position of S14. By switching to CONTACT the 0V connection is removed from the junction of R39 with R40 and R43 and the p.d. at this point establishes a positive bias at the inputs to Q11 and Q12, thus relieving the user of any obligation to provide a voltage level.

"Contact Bounce" Filtering in D.C. Amplifiers

4.53 To minimise the effects due to "contact bounce" in the user's equipment, a filter capacitor may be connected in parallel with R44 ('A' Channel) or R45 ('B' Channel). Pins 41/42 and 39/40 are provided to facilitate the fitting of such a capacitor. The capacitor should be of a ceramic type; the capacitance value is not critical and is dependent upon the degree of contact bounce occurring in the user's equipment, values in the range $.01 \mu\text{F}$ to $0.1 \mu\text{F}$ will generally prove adequate. It should be noted, however, that the frequency response of the d.c. amplifiers will be affected by the fitting of such filter capacitors and the capacitance value therefore should not be larger than necessary.

TRIGGER SLOPE SELECTION

Introduction

4.54 Trigger Slope selection enables the user to choose the required polarity of triggering edge on the input waveform. The input signals are supplied via the d.c. amplifiers, shaped in the Schmitt Trigger IC23a ('A' Channel) or IC23b ('B' Channel) and applied to slope selection gates (Area D in Fig. 4.6). The gating network is offered a choice of inverted or non-inverted signals from each channel, and the appropriate gate is opened according to the logic levels supplied via the associated Trigger Slope switches, S13 (START) or S12 (STOP), thereby determining the polarity of the signal which is to trigger the main control circuit. Three output lines are provided, a general "Start"

line via IC21c and separate "Stop" lines for Time Interval Single-Line (IC21f) and Time Interval Double-Line (IC22c). These lines are active simultaneously, it being the function of the main control circuit gating (IC1c, IC7d/IC7e) to direct the use of these Start/Stop signals.

Trigger Slope Switching

4.55 The logic levels for control of the slope selection gates are provided by switches S12 and S13 in conjunction with +5V and resistors R37/R38. With S12 and S13 in the positions shown in Fig. 4.4, the lines via pin 30 and pin 31 of the Motherboard are at 0V, this logical '0' applying a closure to IC22a/13, IC21d/3 and IC21a/13 with the alternative polarity gates being opened by a '1' from the inverters IC20b and IC20c. In the opposite positions of the switches, however, R37 and R38 will be disconnected from 0V and these control lines will rise towards +5V, thus reversing the logic signals just referred to. The START switch S13 operates only on the slope gates for the Start signal (IC21a/IC21b) but since there are two Stop lines the switch S12 is connected to both pairs of "Stop" slope gates (IC22a/IC22b and IC21d/IC21e).

Slope Selection Signal Paths

4.56 The signal paths through the Slope Selection gates may be summarized by the following table in conjunction with Area D in Fig. 4.6.

<u>Signal</u>	<u>Input Channel</u>	<u>Inverter</u>	<u>Slope Switch Setting</u>	<u>Slope Selection Gates</u>	<u>Output</u>
"Stop" (D/L)	"A"	IC20a		IC22a/1 } IC22b/10 }	IC22c
"Stop" (S/L)	"B"	IC20d		IC21d/2 } IC21e/4 }	IC21f
"Start" (Both Lines)	"B"	IC20d		IC21a/1 } IC21b/10 }	IC21c

COUNTER DISPLAY ASSEMBLY : 19-0632 Fig. 4.2

4.57 This Assembly is of conventional design, consisting of a chain of six BCD decade counters (IC13 to IC18) each decade producing a four-line output with 8-4-2-1 weighting, which drives the associated indicator tube (V1 to V6) via a b.c.d.-to-decimal decoding and driving stage (IC1 to IC6). At customer's option provision is made for the fitting of a latch package (IC7 to IC12) in the b.c.d. output from each decade. With the latch option the output from the latch packages is stored whilst the counters are accumulating a new measurement. On receipt of the transfer pulse from the Main Control Circuit, via pin 12, the counter information is released to update the display. The four-line b.c.d. output from each counter decade is made available for data printout via the 180 ohm resistors R14 to R37, the required connections to the rear panel of the instrument being available under Option 01.

4.58 Decimal point (d.p.) information is provided in the indicator tubes V1, V2 and V3 when a logical '1', received from the Motherboard via pins 6, 7 or 8, turns on the appropriate transistor Q1 to Q3. The d.p. drive signal is also available for data readout via R10 to R12. (Option 01). Also with Option 01 the +5V supply is available for use in a data readout system via R13.

NOTE ON OPTION 01:

In early deliveries of the instrument the latch packages of Option 03 are fitted whenever Option 01 is called for.

POWER SUPPLY

Introduction

4.59 The power supply circuit is shown in Area L in Fig. 4.6. The bulkier items, such as mains transformer, are attached to the main chassis whilst rectifiers and stabilizing components are mounted on the Motherboard. Soldered tappings on the transformer provide for operation from 100 - 130V or 190 - 260V a.c. supplies. The d.c. outputs are +200V for indicator tubes, and stabilized +5V and -6.8V to the Motherboard, the +5V also being supplied to the Counter Display Assembly.

4.60 The a.c. power is connected by a plug and socket to the Mains Filter Assembly via the surge-resisting fuse FS11, which is accessible on the rear panel. From the mains filter the a.c. input is routed via the front panel POWER switch to the mains transformer T1.

Rectifiers and Stabilizing Circuit

4.61 The +5V system employs a full-wave rectifier D11 with fuse FS2 on the output. The value of FS2 differs in 9835 and 9837. Stabilization is by a conventional regulating system consisting of series transistor Q51 (mounted on the rear panel to ensure adequate heat

dissipation) reference zener diode D9, the driver Q24 and amplifier Q23. Any variation of the +5V output level is detected by Q23 and a correcting signal is applied via Q24 to Q51. The system is pre-set to +5V by potentiometer R103; it is important that this adjustment is made with the voltage selector correctly set for the supply.

4.62. The -6.8V output is provided by the rectifier D12 with simple stabilization provided by zener diode D8. Rectification of the +200V is provided by D10, which provides an unstabilized output to the anodes of the numerical indicator (Nixie) tubes.

H.F. DIVIDER ASSEMBLY 19-0666 (Fitted in 9837 only)

Signal Path

4.63 The signal from pin 49 on the Motherboard enters the H.F. Divider Assembly at pin 1 and is applied via emitter-follower Q1 to the pulse amplifier Q2. From Q2 the signal is offered two parallel paths as follows:-

- (a) The "division" path is via the high-speed Schottky TTL package IC4a/IC4b, arranged as a divide-by-four stage, to the gate IC1a.
- (b) The "straight-through" path is direct from Q2 to the gate IC1c.

The particular signal received by the output amplifier Q3 is determined by the state of the gates IC1a and IC1c, these gates being controlled by logic levels applied to pin 4 of the p.c.b. from the Function switch and to pin 3 from the H.F. switch (LEVEL control).

Reference Frequency Path

4.64 The 1 MHz reference signal is processed in a manner similar to the h.f. signal except that no input amplifiers are required. The signal entry to the p.c.b. at pin 5 is followed by division-by-four in the conventional D-type package IC3a/IC3b. The straight-through path is via the gate IC2a to IC2b. Selection between divided or non-divided output is made by the switched logic levels described in the next paragraph.

Switching Logic

4.65 Switching levels are applied to pins 3 and 4 of the p.c.b. A logical '1' applied to either pin 11 or 12 of IC2d will enable the straight-through paths, that via IC2a and IC2b for the 1 MHz reference and via IC1c and IC1b for the h.f. signal. This is the condition for all Functions except FREQUENCY, because the Function switch will maintain a '1' in all modes except FREQUENCY.

4.66 With the Function switch set to FREQUENCY a logical '0' will be applied to pin 11 of IC2d, but the straight-through condition will be maintained until a '0' also appears on pin 12 of IC2d, which occurs when the LEVEL control is switched to "HF". With both inputs to IC2d now at '0' the gates IC1c and IC2a will close and IC1a and IC2c will open, thus releasing the divided outputs to the Motherboard.

CHAPTER 5

MAINTENANCE

INTRODUCTION

5.1 This chapter contains information under the following main headings:-

(a) Instrument Self-Check Procedure

Commencing at paragraph 5.2, these tests provide a check-out procedure, without use of test instruments, which may be used at any time to verify operational serviceability.

(b) Test Equipment Required

List of test instruments required for calibration procedures is given in Table 5.1.

(c) Dismantling Instructions

Refer to paragraph 5.8.

(d) Calibration

Commencing at paragraph 5.10 tests are given to check power supply adjustments, frequency and sensitivity measurements and oscillator alignment. These tests are recommended for use in an overhaul or fault finding procedure.

SELF-CHECK PROCEDURES

NOTE: It is assumed that the instrument has been prepared for use as instructed in Chapter 2. Unless stated otherwise, digital readouts will have the normal tolerance of one count.

FREQUENCY CHECK

5.2 (1) Set the following controls:-

- (a) Function switch to FREQUENCY 'A'.
- (b) DISPLAY TIME fully anti-clockwise in SINGLE SHOT position.
- (c) Depress the n(1) push-button.

- (2) Press the RESET button and verify that the display reads 0001.00.
- (3) Select the n (10) push-button.
- (4) Press the RESET button and verify that the display changes to 001.000.
- (5) Rotate the DISPLAY TIME clockwise from the switched SINGLE SHOT position to the minimum variable position.
- (6) Depress the remaining Range push-buttons in turn and verify that the following readings are obtained.

<u>RANGE</u>	<u>DISPLAY</u>	<u>Tolerance</u>
kHz (10^2)	01000.0	
kHz (10^3)	1000.00	
kHz (10^4)	000.000	+ 1 count
Hz (10^5)	00000.0	

PERIOD CHECK

- 5.3 (1) Set the Function switch to PERIOD 'A'.
- (2) Check that DISPLAY TIME is not set to SINGLE SHOT.
- (3) With CHECK selected, depress each Range push-button in turn and verify that the following readings are obtained.

<u>RANGE</u>	<u>DISPLAY</u>	<u>Tolerance</u>
ms (1)	000.001	
μ s (10)	00001.0	
μ s (10^2)	0001.00	
μ s (10^3)	001.000	+ 1 count
ns (10^4)	01000.0	
ns (10^5)	1000.00	

TIME INTERVAL CHECKS

5.4 Time Interval - B

- (1) Set the Function switch to TIME INTERVAL 'B'.
- (2) Check that DISPLAY TIME is not set to SINGLE SHOT.
- (3) With CHECK selected, depress each Range push-button in turn and verify that the decimal point positions are as follows:-

<u>RANGE</u>	<u>DISPLAY</u>	<u>Remarks</u>
ms (1)	000.000	
ms (10)	0000.00	
ms (10^2)	00000.0	Observe D.P. position
sec (10^3)	000.000	
sec (10^4)	0000.00	
sec (10^5)	00000.0	

- (4) Press the START button.
- (5) Observe the display and verify that the count 'clocks' in 0.1 second increments (i.e. 10 digits per second).
- (6) Press the STOP button and check that the display resets to all zeros after an appropriate period as set by the DISPLAY TIME control.

5.5 Time Interval B → A

- (1) Set the Function switch to TIME INTERVAL B → A.
- (2) Repeat operations (3) to (6) of para. 5.4.

RATIO CHECK

- 5.6 (1) Connect the 1MHz OUTPUT socket on the rear panel to the 'B' input socket on the front panel using a coaxial lead.
- (2) Set the Function switch to RATIO $n \frac{A}{B}$
- (3) With CHECK selected, depress the $n (10^3)$ Range push-button.
- (4) Verify that a readout of 001000 is obtained.

TOTALIZE CHECK AND AMPLIFIER SERVICEABILITY CHECK

- 5.7
- (1) Connect the 1 MHz signal as in para. 5.6 (1).
 - (2) Set the Function switch to TOTAL $\frac{A}{n}$.
 - (3) With CHECK selected, depress the n (1) Range push-button.
 - (4) Verify that a readout of 000001 is obtained with a tolerance of +1, -0.
 - (5) Operate both of the TRIGGER SLOPE switches and the PULSE/CONTACT switch and verify the same reading as in (4) for any combination of these switches.
 - (6) Release the CHECK push-button.
 - (7) Transfer the 1 MHz connector from the 'B' input to the 'A' input socket.
 - (8) Set the AC/DC switch to AC.
 - (9) Rotate the LEVEL control fully anti-clockwise.
 - (10) Press the START button and verify that a display at 1 MHz rate is obtained.
 - (11) Rotate the LEVEL control fully clockwise and note that counting ceases.
 - (12) Set the AC/DC switch to DC.
 - (13) Press the STOP button and verify that the display resets to zero after an appropriate display time.
 - (14) Depress the n (10^3) Range push-button and turn the DISPLAY TIME control to the SINGLE SHOT position.
 - (15) Operate the START and STOP buttons repeatedly and verify that the successive counts are accumulated by the display.

DISMANTLING INSTRUCTIONS

Removal of Case

- 5.8 Unscrew the two captive 'pozidriv' screws which are recessed in the plastic "feet" on either side of the rear panel. The chassis can then be withdrawn.

Removal of Readout Board

- 5.9a Remove the two screws which are located towards the rear of the board. Slide the board back to clear the front retaining slot and lift upwards, removing the board as far as the wiring will allow. This will permit access to the Motherboard.

Removal of H.F. Divider Board (9837 Only)

5.9b Tests on the board should be made "in situ". To remove the board, extract the two retaining screws and unsolder connecting wires as necessary.

TABLE 5.1
TEST EQUIPMENT

TEST EQUIPMENT	BRIEF SPECIFICATION	SUITABLE MODEL
Multimeter	20 000 ohm/volt. AC/DC 0-250V D.C. 2% f.s.d.	AVO Model 8
L.F. Signal Generator	Range 15 Hz - 15 MHz 5 mV - 2V r.m.s.	Racal-Airmec 399
H.F. Signal Generator	30kHz-20MHz (up to 60MHz for 9837) Output: 1mV - 1.1V r.m.s.	Racal-Airmec 201A (30MHz) or Type 407 (80MHz)
Oscilloscope (general purpose)	Bandwidth: d.c. to 40MHz Sensitivity: approx. 50mV/cm	Tektronix 543 or 543
H.F. Millivoltmeter	0 to >500MHz 1mV to 300mV	Racal CT569
PULSE GENERATOR	1kHz - 1MHz, with 100ns to 100µs pulse width. Amplitude 50mV to 3V approx, calibrated to 10% or better.	
1MHz FREQUENCY- STANDARD	Nominally 1V r.m.s. with an accuracy of ± 1 part in 10^8 .	
<u>ACCESSORIES</u>		
(a) 50Ω coaxial leads, BNC to BNC connectors. (i) Three at 3 ft (1 metre) length, approximately. (ii) One at 2 ft (60 cm.) length, approximately.		
(b) Three BNC 'T' pieces.		
(c) One BNC 50Ω terminating pad.		

CALIBRATION

POWER SUPPLY CHECKS

- 5.10 (1) Check that the transformer tapings are correct for the supply voltage.
- (2) Connect the mains supply and set the POWER switch to ON.
- (3) Using the multimeter, check d.c. voltages at the following test points and make adjustments, if necessary, to obtain the required reading.

TABLE 5.2a
Power Supply Tests

<u>Test Point</u>	<u>Required Reading</u>	<u>Adjustment</u>
Counter/Display Assembly: pin 37	+ 200V within $\pm 15V$	None
Counter/Display Assembly: pin 5	+ 5V within $\pm 0.25V$	} Adjust R103 on Motherboard
Motherboard: Test point TP6	- 6.8V within $\pm 0.4V$	

TABLE 5.2b

Fuses

<u>Fuse Function</u>	<u>Location</u>	<u>Value</u>
A.C. Supply	Rear Panel	125 mA - 200-240V 250 mA - 100-125V antisurge
D.C.	Internal	FS1 - 60 mA FS2 - 1A in 9835 1.25A in 9837 } quick action

FREQUENCY AND SENSITIVITY CHECKS

NOTE: Instructions for the use of the LEVEL control include the word "variable". This indicates to users of the 9837 that the "H.F." (switched) position of the control is not to be used although the instruction may say "fully anti-clockwise".

FREQUENCY MODE

5.11 Equipment Required (See Table 5.1)

Signal Generator
Millivoltmeter
BNC 'T' piece with 50 Ω termination

5.12 Procedure

- (1) Set the Instrument controls as follows:-
 - (a) AC/DC switch to AC.
 - (b) LEVEL control fully anti-clockwise (variable) position.
 - (c) DISPLAY TIME to minimum variable (anti-clockwise)
 - (d) Function switch to FREQUENCY - A.
- (2) Connect the signal generator to the 'A' input socket using 'T' piece and 50 ohm termination.
- (3) Refer to Table 5.3 below. Select each Range push-button and apply the corresponding signal generator input frequency, the 10mV level in each case to be accurately adjusted by millivoltmeter measurement.
- (4) At each input frequency check for stable and accurate readout.

TABLE 5.3

9835 (and 9837 up to 20 MHz)		
Range Push-button Selected	Input Frequency	Input Level
MHz (1)	20 MHz) 10mV r.m.s. checked by millivoltmeter
MHz (10)	20 MHz	
MHz (10 ²)	10 MHz	
kHz (10 ³)	1 MHz	
kHz (10 ⁴)	1 kHz 100 kHz	
Hz (10 ⁵)	15 Hz	
9837 Only, With LEVEL control set to "H.F."		
kHz (10 ³)	1 MHz) 10mV r.m.s.
MHz (1)	30 MHz	
MHz (1)	60 MHz	

- (5) Set the AC/DC switch to DC. In the 9837 set the LEVEL control to a variable position.
- (6) With an input frequency of 15 Hz increase the input amplitude to 1V r.m.s. and check that the 15 Hz readout is maintained.

- (7) To check the LEVEL control proceed as follows:-
- (i) Set the AC/DC switch to AC and select the MHz (n = 1) range push-button.
 - (ii) Apply 15 MHz at approximately 10mV to the 'A' channel input socket.
 - (iii) With the LEVEL control set fully anti-clockwise (variable) check for a stable display.
 - (iv) Increase the signal generator output level to 500mV approx.
 - (v) Turn the LEVEL control clockwise and verify that in the fully clockwise position the count has stopped.

PERIOD MODE

- 5.13 (1) Set the Function switch to PERIOD-A and the remaining controls as in para.5.12.
- (2) Connect the signal generator to the 'A' input socket using 'T' piece and 50 ohm termination.
- (3) Refer to Table 5.4 below. Select Range buttons and input frequencies and for each setting monitor several displayed readings.

TABLE 5.4

Range Push- Button Selected	Input		Tolerance
	Frequency	Level	
n (1)	15 Hz) 50mV r.m.s.	±0.3% of reading
n (1)	50 Hz) checked	±0.3% of reading
n (1)	100 Hz) by milli-	±0.3% of reading
n(10)	100 Hz) voltmeter	±0.03% of reading

RATIO Mode

5.14 Equipment Required

As listed in para.5.11 plus two BNC-to-BNC coaxial leads and an additional 'T' piece.

5.15 Procedure

- (1) Set the controls as follows:
 - (a) Function switch to $\text{RATIO } n \frac{A}{B}$
 - (b) AC/DC switch to DC.
 - (c) Both TRIGGER SLOPE switches to 
 - (d) DISPLAY TIME to minimum variable (anti-clockwise).
- (2) Fit BNC 'T' pieces to the 'A' and 'B' input sockets and join the two 'T' pieces with the short length of BNC-to-BNC coaxial cable.
- (3) Fit a 50 ohm load to one 'T' piece and connect the signal generator output to the other, so that input is applied to both channels simultaneously with termination in 50 ohms.
- (4) Apply a 2MHz signal at a level of 1 volt r.m.s. and verify that with n(1) Range button depressed the display reads 000001 with a tolerance of +1 count.
- (5) Depress the n(10) to n(10⁵) Range buttons in turn and verify that "times 10" readings are displayed with a tolerance of +1 count.

TIME INTERVAL Modes

5.16 Equipment Required

- (a) Oscilloscope
- (b) Pulse Generator
- (c) Three BNC 'T' pieces and a 50 ohm load.
- (d) Two BNC-to-BNC coaxial leads.









5.17 Time Interval-'B' Channel

- (1) Set the controls as follows:
 - (a) Function switch to TIME INTERVAL-B
 - (b) DISPLAY TIME to minimum variable (anti-clockwise).
 - (c) PULSE/CONTACT switch to PULSE
 - (d) Select n(1) Range push-button.

5.17 Cont'd.

- (2) Using two BNC 'T' pieces connect the Pulse Generator, the oscilloscope and a 50 ohm termination to the 'B' channel input socket.
- (3) Apply a positive-going pulse of 100 μ sec. width and 1kHz p.r.f.
- (4) Increase the pulse height relative to ground to obtain a stable readout. Check that the pulse height is +1 volt \pm 0.25V.
- (5) Increase the pulse height to +2 volts and check the readout with various settings of the TRIGGER SLOPE switches, as in Table 5.5 below.

TABLE 5.5

TRIGGER SLOPE SWITCHES		READOUT	TOLERANCE
START	STOP	(milliseconds)	
		1.0)
		0.1)
		1.0)
		0.9)
) All
) \pm .02 millisecs.

- (6) Set the PULSE/CONTACT switch to CONTACT and verify that the reading of 0.9 millisecs is unchanged. Reset PULSE/CONTACT switch to PULSE.
- (7) Reduce the pulse width until the unit is just counting correctly and check that the pulse width is less than 50 nanosecs measured at the +1 volt (half pulse height) level.
- (8) Continue with the Time Interval B-A check in the next paragraphs.

5.18 Time Interval - Double Line

NOTE: The equipment required is listed in para. 5.16.

- (1) Refer to para. 5.16 operation (2) and with an additional 'T' piece and a short BNC-to-BNC lead connect the test equipment and load to both input sockets.

- 5.18 (2) Set the Function switch to TIME INTERVAL B-A and the AC/DC switch to DC. The other control settings as in para. 5.16 (1).
- (3) Repeat the tests as for Time-Interval-B, (Para. 5.17 operations (3) to (7)).
- (4) The test equipment should remain connected for the "Totalize" checks.

TOTALIZE Mode









5.19 Equipment Required

As for Time Interval. (See para. 5.16).

5.20 Procedure

- (1) Connect the test equipment as for Time Interval-B (para. 5.17(1)).
- (2) Set the Function switch to TOTAL $\frac{A}{n}$.
- (3) Depress the CHECK push-button and repeat the tests as detailed for Time Interval-B. (para. 5.17), but referring to Table 5.6 below for the readout details.

TABLE 5.6

TRIGGER SLOPE SWITCHES		READOUT	TOLERANCE
START	STOP		
		001000) All ±20 digits
		000100	
		001000	
		000900	

- (4) In addition:-
- (a) Release the CHECK button.
- (b) Press the START button and observe a continuous count.
- (c) Press the STOP button and verify that an arbitrary count is displayed and reset.

- (5) Test equipment may remain connected for Display Time check.

DISPLAY TIME CHECK

- 5.21
- (1) With a suitable signal applied to the 'A' channel input, operate the instrument as for Totalize mode.
 - (2) Set the DISPLAY TIME control to minimum variable (anti-clockwise) position.
 - (3) Depress the START and STOP buttons in turn to display an arbitrary count. Verify that display time is approximately 250 milliseconds.
 - (4) Turn the DISPLAY TIME control fully clockwise, repeat operation (3) and verify that display time is not less than 4 seconds, typically 7 seconds.
 - (5) Turn the DISPLAY TIME control fully anti-clockwise to the SINGLE SHOT (click) position. Then depress the RESET button verifying that this clears the display and provides a new count.

INTERNAL FREQUENCY STANDARD

CAUTION: Allow a warm-up period of not less than one hour before making this check.

5.22 Equipment Required

- (a) 1 MHz External Frequency Standard accurate to ± 1 part in 10^8 and with output level 1 volt r.m.s.
- (b) Oscilloscope

5.23 Calibration Procedure

- (1) Connect the 1 MHz External Frequency Standard to the EXT trigger input of the Oscilloscope.
- (2) Set the Oscilloscope controls to "EXT TRIGGER" and to 1 μ sec/cm Time Base".
- (3) On the rear panel of the 9835/9837 set the switch to INT and connect the oscilloscope probe to the socket "1 MHz O/P".

- (4) Observe the oscilloscope display for 10 seconds and check that less than one cycle of the displayed waveform passes a fixed mark on the c.r.t. in this time. If necessary adjust the trimmer C21 on the Motherboard to achieve this accuracy.

NOTE: When the fast-warm-up oscillator is fitted (Option 04) the adjustment is made in the oscillator unit via a hole in the rear panel.

- (5) Disconnect the external frequency standard from the oscilloscope and transfer it to the 1 MHz I/P socket on the 9835/9837.

External Standard Input Check

- 4.24
- (1) Set the controls as follows:-
 - (a) Function switch to FREQUENCY-A.
 - (b) Depress the CHECK push-button.
 - (c) Depress the "kHz (10^3)" Range push-button.
 - (d) Set the rear panel slide switch to EXT.
 - (2) From the external frequency standard apply a signal of 1 MHz at not less than 100mV r.m.s. to the rear panel socket "1MHz I/P".
 - (3) Verify that the counter readout is 1000.00, (tolerance ± 1 count).
 - (4) Disconnect the external frequency standard.

Internal Standard Output Check

- 5.25
- (1) Set the rear panel slide switch to INT.
 - (2) With instrument switched on and thoroughly warmed up, check with an oscilloscope at the rear panel socket "1MHz O/P" for a rectangular waveform at 1 MHz with amplitude not less than 1 volt peak-to-peak.

DATA READOUT CHECK (When Option 01 fitted)

5.26 Equipment Required

- (a) Printer, or Print Simulator
- (b) Signal Generator.

Procedure

- (1) Connect the Printer (or Print Simulator) via the 36-way BCD connector on the rear panel.
- (2) With 50-ohm termination apply an input from a signal generator to the 'A' input socket.
- (3) Operate the instrument as for FREQUENCY mode and display all digits in turn.
- (4) Verify that Printer (Simulator) readout (six digits) is identical to that of the unit under test.
- (5) Check that decimal points are correctly positioned for change in Range buttons/Function switch selections. (There are no d.p. on RATIO or TOTAL).
- (6) Check that the instrument display is "held" during the print-out period. (Print Simulator PRINT lamp illuminated).
- (7) Disconnect all test gear.

SECTION 3

PARTS LIST

ORDERING OF SPARE PARTS

1. To be assured of satisfactory service when ordering replacement parts, the customer is requested to include the following information.
 - (a) Instrument type and serial number.
 - (b) The type reference of the Assembly in which the particular item is located.
 - (c) The Racal Part number and circuit reference of each item being ordered.

It should be noted that a minimum charge of £5 sterling is applicable to all orders.

2. The name of the manufacturer (Vendor) quoted in the right-hand column of the Parts List is for general information only. Racal Instruments Limited, reserves the right to supply an equivalent or improved part by another manufacturer, if necessary.

PARTS LIST

CONTENTS

	<u>Page</u>
Main Chassis Assembly ... (11-0741)	6-2
Mains Filter Assembly ...	6-3
Counter Display Assembly ... (19-0632)	6-3
Motherboard Assemblies ... (See NOTE (b) below)	6-4 to 6-7
H.F. Divider Assembly ... (19-0666) (9837 only)	6-8

NOTES

Replacement Resistors

The Erie Type 15 composition resistor which has a 0.4 inch (10mm) lead spacing may be replaced by the Mullard Type CR16 carbon film type. In cases where the printed circuit board has resistor mounting holes with 0.5 inch (12.5mm) spacing, the recommended replacement resistor is the Mullard CR25, 330mW, carbon film type. The Mullard CR25 may also replace those $\frac{1}{4}$ watt 5% metal oxide resistors which have 0.5 inch hole spacing.

Models 9835 and 9837

Parts List details are common to both instruments, except for the following:-

- (a) Minor differences in Main Chassis components (see page 6-2).
- (b) A few differences in Motherboard components. Parts List 19-0633 refers to the 9835. A few components will differ in the 9837; refer to page 6-7 for details of the 9837 (Motherboard Type 19-0668).
- (c) The H.F. Divider Assembly is fitted only in the 9837.

Mullard CR25 Resistors

Although these resistors are rated at 330mW the user may fit a suitable $\frac{1}{4}$ watt resistor whenever a CR25 is not available.

Part No.	Description	Rat.	Tol. %	Value	Component References	Vendor/Type
----------	-------------	------	--------	-------	----------------------	-------------

MAIN CHASSIS ASSEMBLY (Parts List 11-0741 & 11-0773)

NOTE: The following items are located in various parts of the instrument but not on any printed circuit board. Items mounted on printed circuit board assemblies are listed under 19-0740 19-0632, 19-0633, 19-0638 and 19-0666.

Miscellaneous Components: Model 9835

20-6613	Potentiometer, Log, LEVEL control			1M	R151/S20	AB Electronics Type 45
20-6612	Potentiometer, Log (with switch) DISPLAY TIME			470k	R152/S19	AB Electronics Type 45
21-4528	Capacitor: Polyester	400V	20	.047 μ	C51	Mullard C296-AC-A47K
21-0580	Capacitor, Elec.	16V	-10+50	6800 μ	C52	Mullard 071-15682
22-6104	Transistor, high power				Q51	Motorola MJE3055
22-1650	Rectifier, potted bridge				D11	Waycom Varo VS248
23-0043	Fuselink, anti-surge (200-240V)			125mA	FS11	Beswick TDC123/0 125
23-0031	Fuselink, anti-surge (100-125V)			250mA	FS11	Bulgin F286/0.25
23-0044	Fuseholder for FS11			5x20mm (IEC)		Pfisterer 031-1401
23-4013	Switches, push-button START, STOP, RESET				S15, S16, S17	Bulgin Q1639/1
23-4042	Switches, slide - AC/DC, TRIGGER SLOPE, PULSE/CONTACT, EXT/INT				S11, S12, S13, S14, S18	Jeanrenaud 51M/8mm
23-4071	Switch, toggle, POWER (IEC)				S3	Marquadt 1620.0101
23-3194	Receptacle, Mains (IEC)					Otto Heil 6061-1
23-3195	Power plug (mates with 23-3194)					Otto Heil 4010
23-3005	Sockets - coaxial - BNC, UG1094/U				SK1, SK2, SK3, SK4	Amphenol 31-2211
23-3019	Free coaxial plug for SK1-SK4					Amphenol UG/88U
17-4037	Transformer, mains				T1	Racal Insts.
23-8000	Ferrite Bead ('A' Channel Amp. input)				FX1	Mullard FX1242
23-3012	Data Output socket: 36 way (Option 01)					Amphenol 57-40360
23-3008	Plug 36-way, free, data output (Option 01)					Amphenol 57-30360
9440	Alternative Frequency Standard (Option 04)					Racal Insts.

Miscellaneous Components: Model 9837

Miscellaneous chassis-mounted components are identical to those in the Model 9835, except for the LEVEL control, details of which are as follows:-

20-6621	Potentiometer, Log (with switch)			1M	R151/S20	AB Electronics Type 45
---------	----------------------------------	--	--	----	----------	------------------------

Part No.	Description	Rat.	Tol. %	Value	Component References	Vendor/Type
<u>MAINS FILTER ASSEMBLY 19-0740</u>						
17-4059	Choke Assemblies			250 μ H	L1, L2	Racal Insts.
21-0002	Paper	250V		5n+5n	C1	Siemens B81211-A-B33
21-1540	Ceramic	500V	25	4700p	C2	Erie 811

COUNTER DISPLAY ASSEMBLY: 19-0632

Resistors

		watts		Ohms		
20-2102	Carbon Film	0.33	5	1k	R1, R2, R3	Mullard CR25
20-2103	Carbon Film	0.33	5	10k	R4, R5, R6, R7, R8, R9	Mullard CR25

Additional Resistors (Option 01, Data Output)

20-2181	Carbon Film	0.33	5	180	R10 to R37 inc.	Mullard CR25
---------	-------------	------	---	-----	-----------------	--------------

Transistors

22-6057	Silicon: high voltage Nixie driver				Q1, Q2, Q3	Ferranti ZTX.342
---------	------------------------------------	--	--	--	------------	------------------

Integrated Circuit Packages

22-4503	Decade Counter (Selected)				IC13	Racal Insts.
22-4046	BCD to Decimal Decoder/Driver				IC1 to IC6 inc.	Texas 74141
22-4049	Decade Counter				IC14 to IC18 inc.	Type 7490

Additional Integrated Circuits (Option 03, Latched Display)

22-4051	Quadruple Latch				IC7 to IC12 inc.	Type 7475
---------	-----------------	--	--	--	------------------	-----------

Numerical Indicator Tubes

26-1015	Numerical Indicator, side view, 2 d.p.				V1 to V6 inc.	I.T.T. 58705
---------	--	--	--	--	---------------	--------------

Part No.	Description	Rat.	Tol. %	Value	Component References	Vendor/Type
MOTHERBOARD ASSEMBLY 19-0633 (Model 9835)						
(See page 6-7 for Model 9837)						
<u>Resistors</u>						
		watts		ohms		
20-4658	Metal Oxide	1	5	100k	R1	Erie MO6
20-1553	Carbon Film	0.33	10	10M	R2	Mullard CR25
20-2272	Carbon Film	0.33	5	2.7k	R3	Mullard CR25
20-2392	Carbon Film	0.33	5	3.9k	R4, R8, R13, R19	Mullard CR25
20-2103	Carbon Film	0.33	5	10k	R5, R9, R14, R20, R33, R37, R38, R44, R45, R54, R63, R65, R67, R68, R69, R70, R71, R72, R73, R74, R80, R81, R83, R84, R88	Mullard CR25
20-2561	Carbon Film	0.33	5	560	R6, R10, R16, R21	Mullard CR25
20-2181	Carbon Film	0.33	5	180	R7, R11, R17, R22, R66, R93, R95, R96	Mullard CR25
20-2101	Carbon Film	0.33	5	100	R12, R18, R58, R85	Mullard CR25
20-2220	Carbon Film	0.33	5	22	R15	Mullard CR25
20-4029	Metal Oxide	$\frac{1}{4}$	1	22k	R24	Electrosil TR4
20-4030	Metal Oxide	$\frac{1}{4}$	1	33k	R25	Electrosil TR4
20-2221	Carbon Film	0.33	5	220	R26, R77, R78, R92, R101, R109	Mullard CR25
20-2102	Carbon Film	0.33	5	1k	R27, R56, R57, R59, R91, R106	Mullard CR25
20-4011	Metal Oxide	$\frac{1}{4}$	1	470	R28, R29	Electrosil TR4
20-4027	Metal Oxide	$\frac{1}{4}$	1	120	R30	Electrosil TR4
20-4028	Metal Oxide	$\frac{1}{4}$	1	680	R31	Electrosil TR4
20-2471	Carbon Film	0.33	5	470	R32, R34, R50, R51, R62	Mullard CR25
20-2472	Carbon Film	0.33	5	4.7k	R35, R36, R64*	Mullard CR25
20-2222	Carbon Film	0.33	5	2.2k	R39, R61, R75, R76, R79, R86, R87, R89	Mullard CR25
20-2473	Carbon Film	0.33	5	47k	R40, R43, R97	Mullard CR25
20-3222	Metal Oxide	$\frac{1}{2}$	5	2.2k	R41, R42	Erie MO5
20-2331	Carbon Film	0.33	5	330	R48, R49, R110	Mullard CR25
20-2332	Carbon Film	0.33	5	3.3k	R52, R53, R60, R90, R104*	Mullard CR25
20-2152	Carbon Film	0.33	5	1.5k	R46, R47	Mullard CR25
20-2822	Carbon Film	0.33	5	8.2k	R82	Mullard CR25

*NOTE: R64 is 1.2k in earlier models. The value of R104 may be 2.7k. See Note on page 6-5.

Part No.	Description	Rat.	Tol. %	Value	Component References	Vendor/Type
----------	-------------	------	--------	-------	----------------------	-------------

MOTHERBOARD ASSEMBLY 19-0633 (Cont'd)

Resistors (contd)

		watts		ohms		
20-2153	Carbon Film	0.33	5	15k	R55	Mullard CR25
20-2122	Carbon Film	0.33	5	1.2k	R94, R102	Mullard CR25
20-2474	Carbon Film	0.33	5	470k	R98, R99	Mullard CR25
20-2470	Carbon Film	0.33	5	47	R100	Mullard CR25
20-6557	Variable, linear	$\frac{1}{4}$	20	1.5k	R103 (See Note)	Davall 80P/2
20-3102	Metal Oxide	$\frac{1}{2}$	5	1k	R105	Erie MO5
20-3471	Metal Oxide	$\frac{1}{2}$	5	470	R108	Electrosil TR5

NOTE: In some models R103 is 1k in which case a value of 2.7k is preferable for R104.

Capacitors

				F		
21-1525	Ceramic		10	270p	C1, C30, C31, C33	Erie 831.N4700
21-1039	Tantalum	16V	20	22 μ	C2, C13, C35	I.T.T. TAG 22/16
21-1616	Ceramic	12V	20	0.1 μ	C3, C4, C16, C17, C18, C19, C24, C28, C40	Murata DD-600.BC12
21-1038	Tantalum	6.3V	20	47 μ	C5, C6, C8, C10, C12	I.T.T. TAG 47/6.3
21-1517	Ceramic		10	56p	C7, C9,	Erie 831.N1500
21-1516	Ceramic		10	47p	C14, C15, C29	Erie 831.N1500
21-2621	Silver Mica	125V	5	27p	C20 (See Note)	Lemco MS.89/1
21-6030	Trimmer			2-15p	C21	Jackson 5890 Tetfer VPC
21-2631	Silver Mica	125V	5	330p	C22, C23	Lemco MS.89/1
21-1532	Ceramic		20	1000p	C25, C26, C27, C34	Erie 831.K350081
21-1003	Tantalum	25V	20	15 μ	C32	I.T.T. TAG 15/25
21-1528	Ceramic		10	470p	C33	Erie 831.K120051
21-1003	Tantalum	25V	20	15 μ	C36	I.T.T. TAG 15/25
21-4523	Polyester	250V	20	0.22 μ	C37	I.T.T. PMT2R
21-4516	Polyester	250V	20	1.0 μ	C38	I.T.T. PMT2R 1.0M250
21-0512	Electrolytic	25V		100 μ	C39	Erie-Hunt 20102-100-0101-0Z-0250
21-1520	Ceramic	500V	10	100p	C11	Erie 831.N3300

Diodes

22-1029	Silicon				D1, D2, D3, D4, D6, D7	Type 1N4149
22-0001	Germanium				D5	Hughes HD1870

NOTE: The value of C20 is subject to test in the range 22pF, 27pF, 33pF, 39pF.

Part No.	Description	Rat.	Tol. %	Value	Component References	Vendor/Type
<u>MOTHERBOARD ASSEMBLY 19-0633 (Continued)</u>						
<u>Diodes (contd)</u>						
22-1811	Voltage regulator 6.8V				D8	Mullard BZY88-C6V8
22-1810	Voltage regulator 6.2V				D9	Mullard BZY88-C6V2
22-1605	Rectifier:	600V	1A		D10	Texas 1N4005
22-1650	Rectifier, potted bridge,	200V	2A		D11	Waycom Varo VS248
22-1602	Rectifier	100V	1A		D12	Motorola 1N4002
<u>Transistors</u>						
22-6101	F.E.T. N-channel				Q1	Siliconix W300A
22-6017	Silicon: npn High-speed switch				Q2 to Q5 inc. Q7 to Q10 inc. Q13 to Q19 inc. Q21, 22, 23, 25	Type 2N2369 or Ferranti ZTX.313L
22-6041	Silicon npn				Q6, Q24	Mullard BC109
22-6010	Silicon npn				Q11, Q12	Motorola 2N4126
22-6058	Silicon pnp				Q20	Transistron TES014 or SGS BFX 48
<u>Integrated Circuit Packages</u>						
22-4053	Triple 3-input Pos. NAND gate				IC1, IC4	Type 7410
22-4049	Decade Counter				IC2, 3, 10, 11 IC12, 13, 14, IC25	Type 7490
22-4045	Quad 2-input Pos. NOR gate				IC5, IC17	Type 7402
22-4084	4-wide 2-input AND/OR input gates				IC6, IC18	Type 7453
22-4066	Expandable dual 2-wide, 2-input, AND/OR invert gate				IC7, IC9, IC21, IC22, IC24	Type 7450
22-4044	Quad 2-input Pos. NAND gate				IC8, IC15, IC19 IC20	Type 7400
22-4048	Dual-D Bistable				IC16	Type 7474
22-4083	Dual NAND Schmitt Trigger				IC23	Type 7413

Part No.	Description	Rat.	Tol. %	Value	Component References	Vendor/Type
<u>MOTHERBOARD ASSEMBLY (Contd.)</u>						
<u>Miscellaneous Items</u>						
17-0053	Switch rotary: Function				S1	Racal Insts.
17-0087	Switch bank: push-button				S2	Racal Insts.
17-2087	Crystal: 5MHz				XL1	Racal Insts.
23-0000	Fuselink: 60mA				FS1	Bulgin F270 0.060
23-0006	Fuselink: 1A (9835)				FS2	Bulgin F270 1.0
23-0042	Fuselink: 1.25A (9837)				FS2	Tp. Rec. Sprs. 5515
23-0034	Fuseholder					Tp. Rec. Sprs. 5229

MOTHERBOARD 19-0668 (Fitted in Model 9837)

(Parts details are identical to the 9835 (Motherboard 19-0633) except for the following items)

Resistors (changes in value)

20-4075	Metal Oxide	1/4W	1	4.7k	R24	Electrosil TR4
20-4094	Metal Oxide	1/4W	1	6.8k	R25	Electrosil TR4
20-2220	Carbon Film	1/4	5	22	R26	Mullard CR25
20-2681	Carbon Film	1/4	5	680*	R27 (See Note)	Mullard CR25
20-2103	Carbon Film	1/4	5	10k	R33	Mullard CR25
20-4009	Metal Oxide	1/4	2	150	R30	Erie MO4

NOTES: 1. R12 and R18 are not fitted in the 9837.

*2. Value of R27 is selected on test. Alternative 330Ω Part No. 20-2331.

Capacitors

21-1509	Ceramic		10	12p*	C41 (See Note)	Erie 832 N030
20-1517	Ceramic		10	56p	C14	Erie 831 N1500
21-1574	Ceramic		10	120p	C29	Erie YD

NOTE: Alternative values for C41, selected on test, are 27p (21-1513) or 56p (21-1517)

Diode (additional component)

22-1033	Silicon Hot Carrier				D13	Hewlett Packard HP5082-2811
---------	---------------------	--	--	--	-----	--------------------------------

Transistor (change of type)

22-6009	Silicon npn				Q6	Type 2N4124 or Ferranti ZTX.107L
---------	-------------	--	--	--	----	-------------------------------------

Part No.	Description	Rat.	Tol. %	Value	Component References	Vendor/Type
----------	-------------	------	-----------	-------	-------------------------	-------------

H.F. DIVIDER ASSEMBLY: 19-0666

(Fitted in 9837 only)

Resistors

20-2222	Carbon Film	1/3	5	2.2k	R1, R5	Mullard CR25
20-2332	Carbon Film	1/3	5	3.3k	R2	Mullard CR25
20-2221	Carbon Film	1/3	5	220	R3	Mullard CR25
20-2181	Carbon Film	1/3	5	180	R4, R6	Mullard CR25
20-2121	Carbon Film	1/3	5	120	R9	Mullard CR25
20-2472	Carbon Film	1/3	5	4.7k	R7, R10	Mullard CR25
20-2102	Carbon Film	1/3	5	1k	R8	Mullard CR25
20-2471	Carbon Film	1/3	5	470	R11	Mullard CR25

Capacitors

21-1616	Ceramic	12V	10	0.1 μ	C1, C2, C3, C5, C6, C7, C9	Murata DD.600.BC.12
21-1518	Ceramic		10	68p	C4	Erie 831. N2200
21-1516	Ceramic		10	47p	C8	Erie 831. N1500
21-1039		16V	20	22 μ	C10	I.T.T. TAG 22/16

Diodes and Transistors

22-0001	Diode, germanium				D1	Hughes HD1870
22-6017	Transistor, silicon, npn				Q1, Q3	Type 2N2369
22-6059	Transistor, silicon, npn				Q2	Mullard BFX89

Integrated Circuits

22-4044	Quad 2-input Pos. Nand Gate				IC1	Type 7400
22-4045	Quad 2-input Pos. Nor Gate				IC2	Type 7402
22-4048	Dual D Bistable				IC3	Type 7474
22-4093	Dual JK Edge Triggered Bistable				IC4	Texas 74S112

SECTION 4

CIRCUIT DIAGRAMS

AND

LAYOUTS

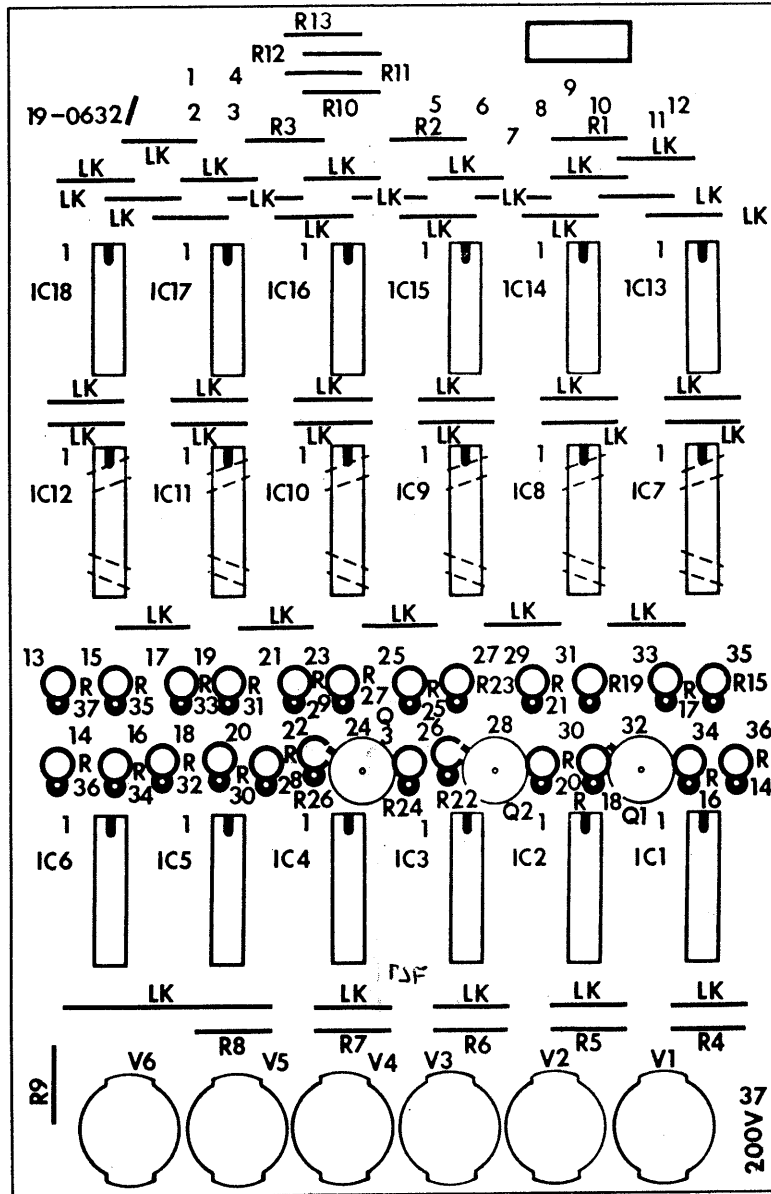
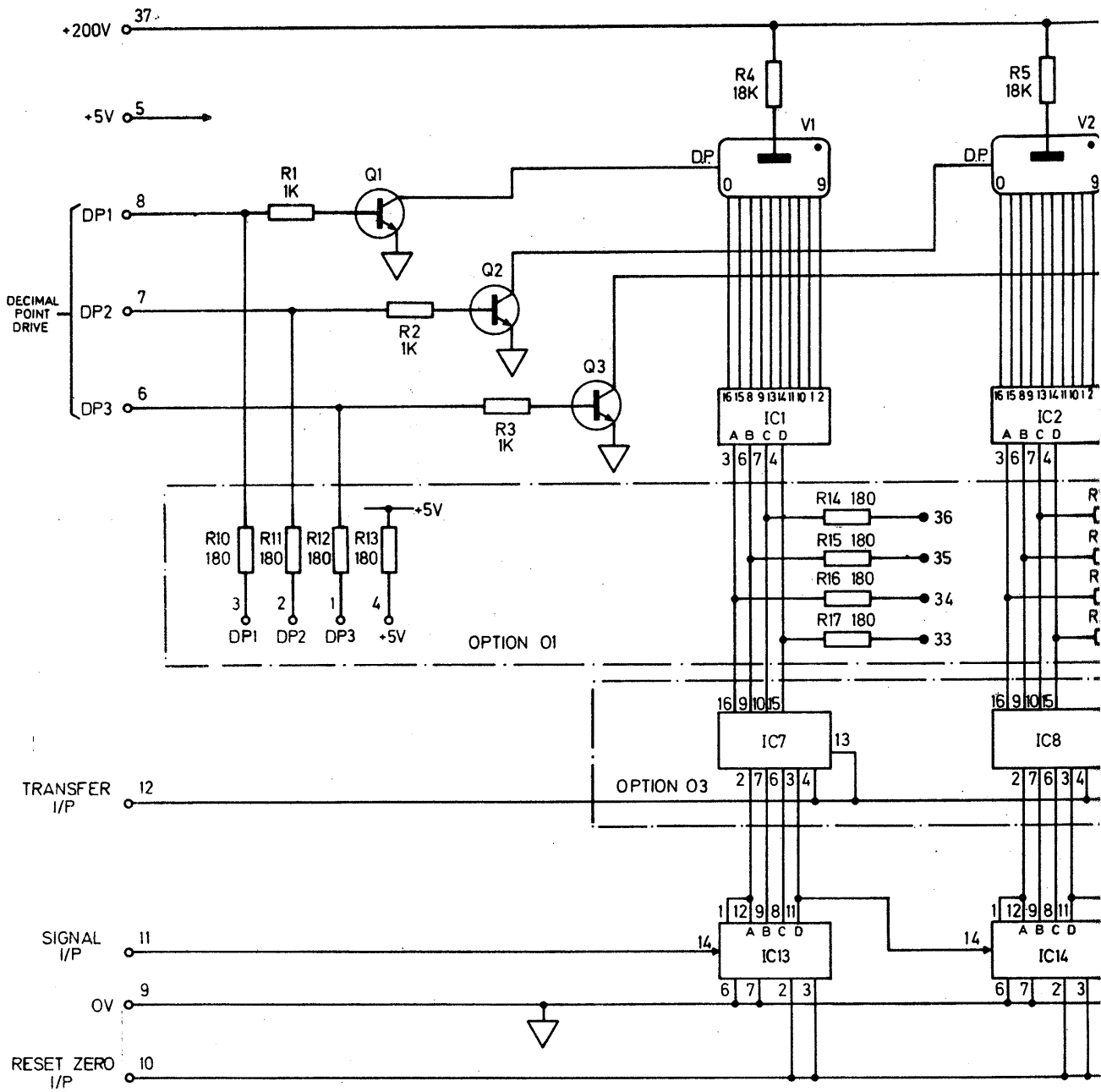
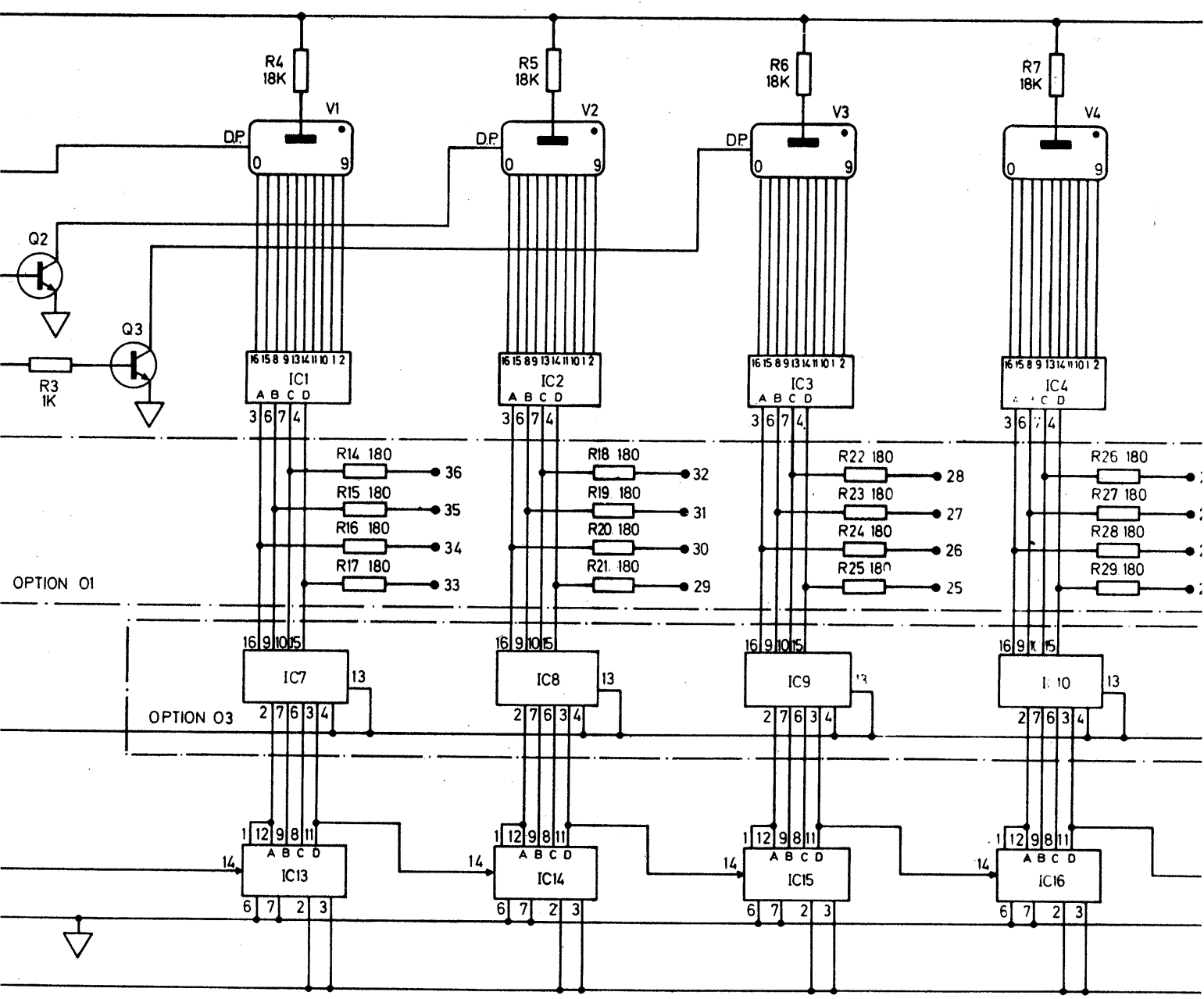

Fig. 4-1

Layout: Counter and Display Assembly
19-0632





Circuit: Counter and Display Assembly 19-0632

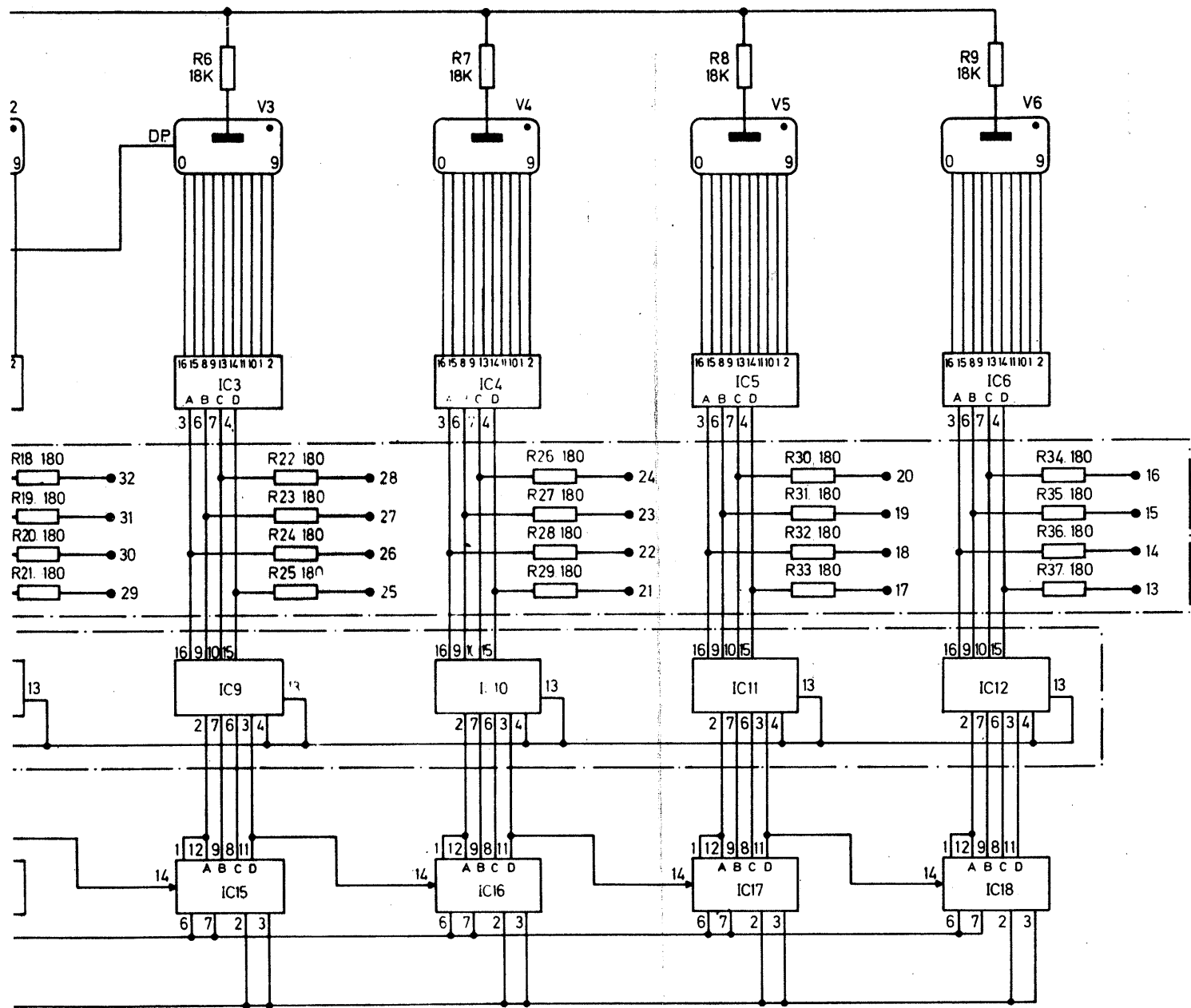

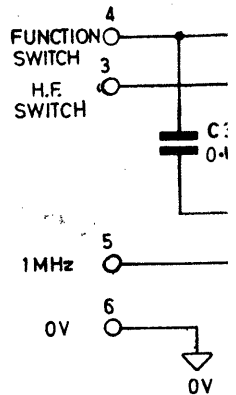
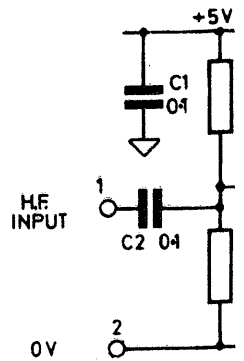
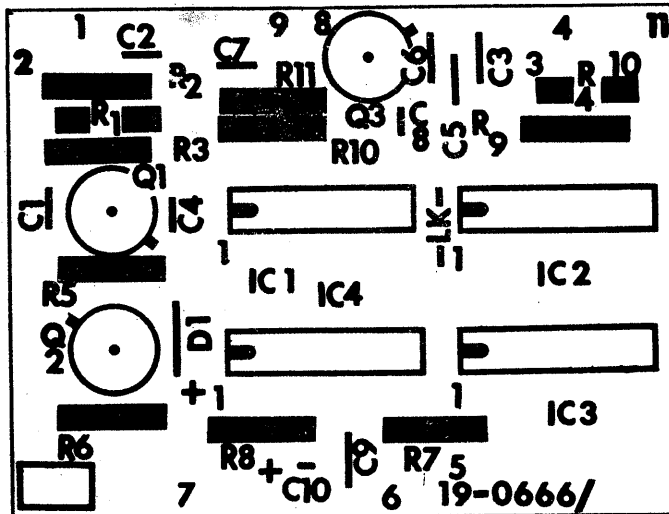

- Q1—
- Q2—
- Q3—
- IC1—
- IC2—
- IC3—
- IC4—

19-0666
1

LAYOUT

Fig. 4-3

19-0666
1

WOH3045

H.F. D

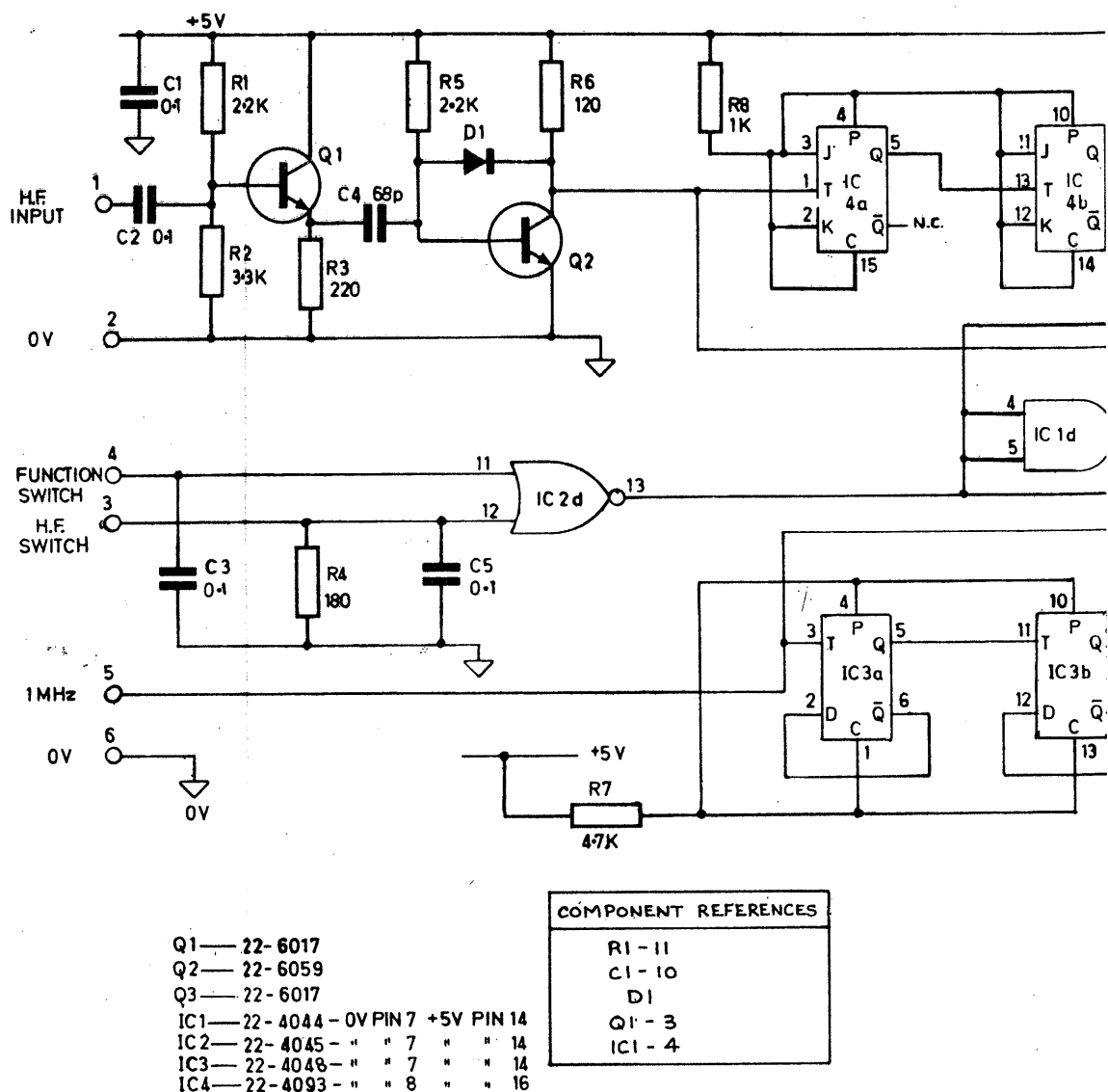

Fig. 4-3

19-0666
1

CIRCUIT

H.F. Divider Assembly 19-0666
(FITTED IN 9837 ONLY)